

REVISIONS			
REV	DESCRIPTION	DATE	APPROVED
A	INITIAL RELEASE ECO 7010	7/2/14	J Kordik
B	REVISE LENGTH ECO 7055	8/28/14	J Kordik
C	ADD LABEL/SPEC CHG ECO 7060	9/15/14	J Kordik
D	REVISE TEXT ECO 7159	3/16/15	J Kordik
E	REVISE SPEC PER ECO 7205	5/8/15	J Kordik
F	ADD UL TO LABEL PER ECO 7330	10/12/15	J KORDIK
G	SPECS REVISED PER ECO 7510	10/19/16	J KORDIK
H	MOTOR REVISED PER ECO 7689	3/14/19	L Liu
I	BREAK CONTACT 170360-1, 8434	3/10/20	L Liu

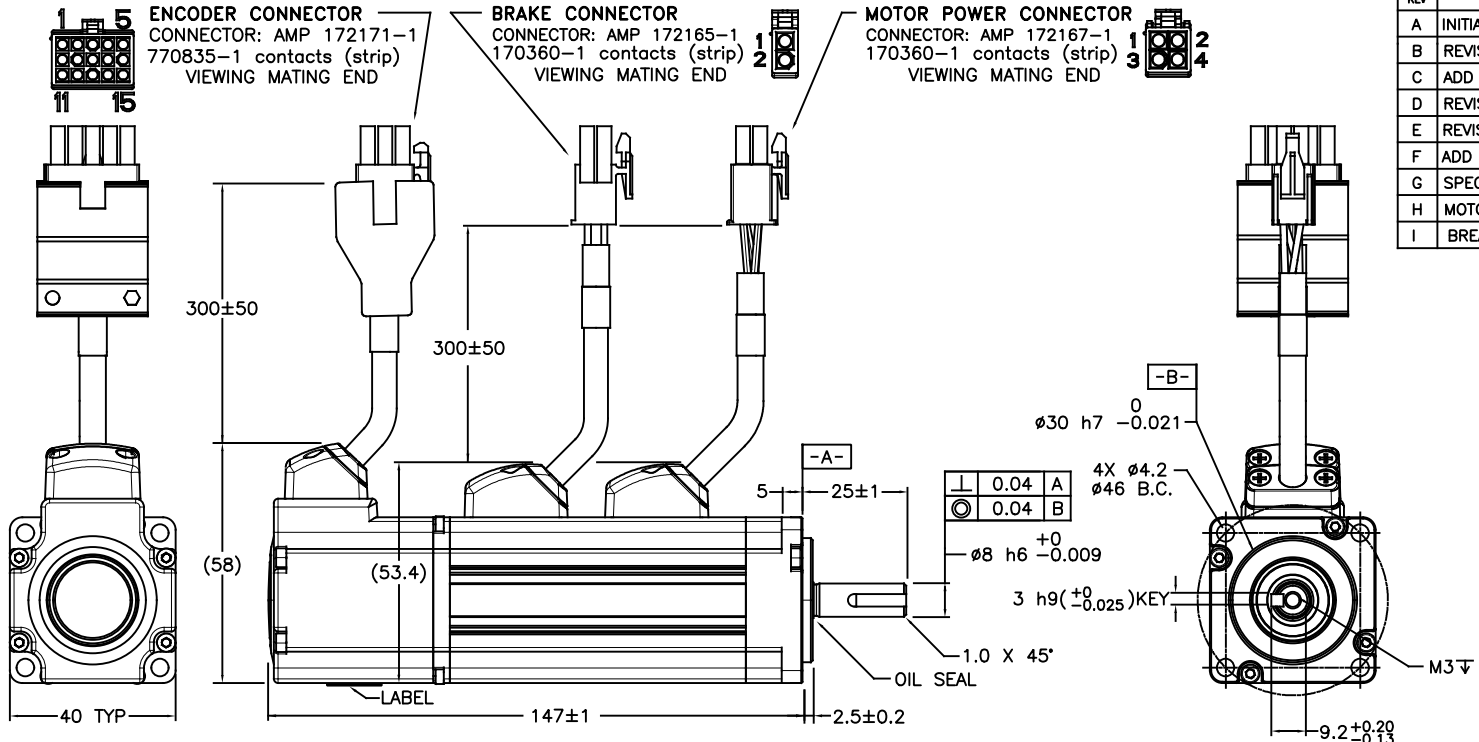

ENCODER CONNECTION TABLE

PIN	LEAD COLOR	SIGNAL
1	RED	+5V
2	BLACK	GROUND
3	BROWN	U+
4	BROWN/BLACK	U-
5	GRAY	V+
6	GRAY/BLACK	V-
7	WHITE	W+
8	WHITE/BLACK	W-
9	BLUE/BLACK	A+
10	BLUE	A-
11	GREEN	B+
12	GREEN/BLACK	B-
13	YELLOW	Z+
14	YELLOW/BLACK	Z-
15	SHIELD	SHIELD

MOTOR CONNECTION TABLE

PIN	LEAD COLOR	SIGNAL
1	RED	PHASE U
2	YELLOW	PHASE V
3	BLUE	PHASE W
4	YELLOW/GREEN	GROUND

BRAKE CONNECTION TABLE

PIN	LEAD COLOR	SIGNAL
1	RED	BRAKE
2	BLACK	BRAKE

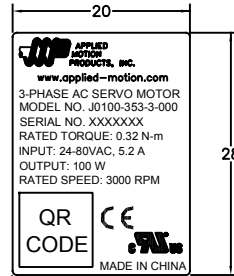

NOTES: UNLESS OTHERWISE SPECIFIED

1. A SHAFT SEAL IS SHIPPED WITH MOTOR, BUT NOT INSTALLED.
2. TIMING LOGIC IS CCW AS VIEWED FROM FRONT SHAFT.
3. MOTOR IS IP65, EXCEPT SHAFT OPENING AND CABLE CONNECTOR.
4. INSTALL INDOORS, AWAY FROM DIRECT SUNLIGHT, FLAMMABLE AND CORROSIVE GASES.
5. 1000M MAX ALTITUDE.
6. BRAKE RELEASES WHILE ENERGIZED, DO NOT ENGAGE WHILE MOTOR IS ROTATING. BRAKE POWER IS NOT POLARITY SENSITIVE. THIS IS A HOLDING BRAKE.

TOLERANCES		THIRD ANGLE PROJECTION		APPROVALS	
DECIMALS: MM (INCH)					
X.XXX = ±0.013 (.005)				DATE	
X.XX = ±0.25 (.01)				DRAWN <i>R.JONEZ</i> 6/17/14	
X.X = ±2.5 (0.1)				CHECKED	
ANGLES:				APPROVED	
MACH. = ±.5°					
CHAM. = ±5°					
COMPUTER DATA				<p>AC SERVO MOTOR WITH ENCODER AND BRAKE</p>	
BASE DRAWING				<p>DWG NO. J0100-353-3-000 REV I</p>	
				SCALE: NONE SHEET 1 OF 2	

AC SERVO MOTOR SPECIFICATION - PERMANENT MAGNET 8 POLES

INPUT POWER SUPPLY	VDC	24-80
RATED OUTPUT	W	100
VOLTAGE CONSTANT	V(rms)/K(rpm)±10%	3.8
RATED WINDING CURRENT	A (rms)	5.2
PEAK WINDING CURRENT	A (rms)	15.6
WINDING RESISTANCE	V ±10%@20°C	0.48 LINE-TO-LINE
WINDING INDUCTANCE	mH ±20%	0.58 LINE-TO-LINE
RATED TORQUE	Nm(kgf-cm)	0.32(3.26)
PEAK TORQUE	Nm(kgf-cm)	0.91(9.28)
TORQUE CONSTANT	Nm/A(rms) ±10%	0.061
RATED SPEED	rpm	3000
MAXIMUM SPEED	rpm	6000
WEIGHT W/ ENCODER & BRAKE	kg (lbs)	0.8 (1.8)
INSULATION CLASS		B 130°C
ENCODER RESOLUTION		2500 LINES/REV.
SHAFT LOAD - AXIAL	N(lbs)(MAX)	50(11)
SHAFT LOAD - RADIAL	N(lbs)(MAX)	60(13.5)
MOTOR RATING	REF NOTE 3	IP65
AMBIENT TEMPERATURE	OPERATING	0 TO 40°C
AMBIENT TEMPERATURE	STORAGE	-20 TO 80°C
AMBIENT HUMIDITY MAX		85%
INERTIA - WITH ENCODER	kg*m ²	0.00000494

6 BRAKE SPECIFICATIONS:

RATED VOLTAGE	24VDC
RATED CURRENT	0.25A
RELEASE VOLTAGE	18.5 VDC MAX (at 20°C)
STATIC FRICTION TORQUE	.35 Nm
ENGAGE TIME	AT NOMINAL AIR GAP (@20°C) <25ms (NEW) FULL RANGE MAX AIR GAP <100ms (WORST COND)
RELEASE TIME	WITHOUT DIODE: <25ms (E-STOP) WITH DIODE: <200ms (NORMAL STOP)

TIMING LOGIC / ENCODER SIGNALS

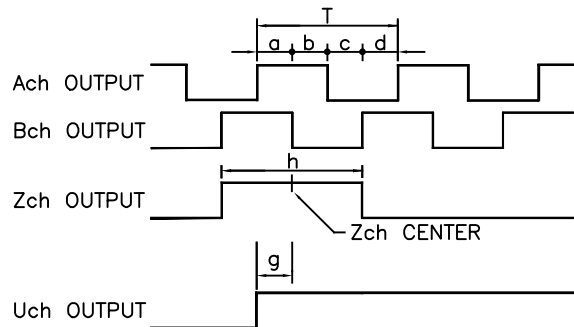

$T = \frac{360 \text{ DEGREES}}{2500C/T}$

$a, b, c, d = T/4 \pm T/8$

$h = T \pm T/2$

TIMING LOGIC / ENCODER SIGNALS

(NOT TO SAME SCALE AS OTHER DETAIL)

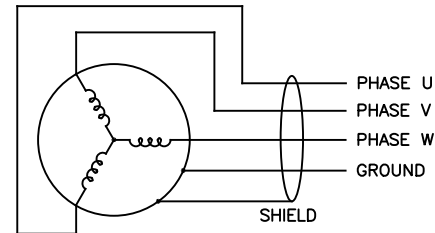
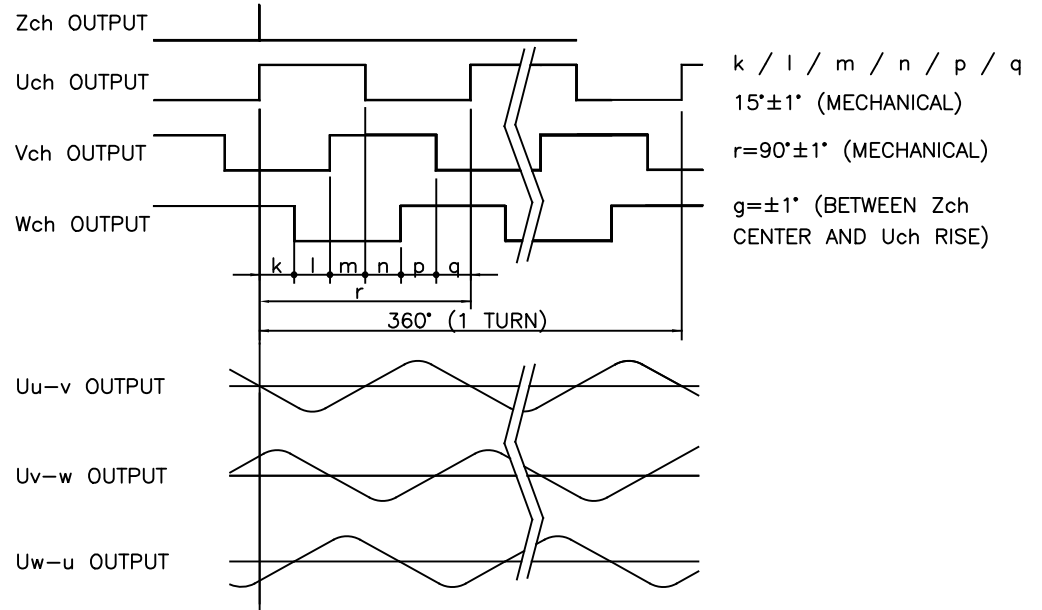

CONTRACT NO.					
APPROVALS				DATE	
DRAWN		<p>SERVO MOTOR SPECIFICATIONS</p>			
CHECKED					
APPROVED		B	FSCM NO.	DWG NO.	REV
APPROVED				J0100-353-3-000	I
		SCALE: NONE			SHEET 2 OF 2