

4

3

2

1

## SPECIFICATION

NUMBER OF PHASES: 2	ROTOR INERTIA: 1.6 g-cm <sup>2</sup> (0.009 oz-in <sup>2</sup> ) NOM
STEPS PER REVOLUTION: 200	DETENT TORQUE: 4 mNm (0.57 oz-in) MIN
STEP ANGLE: 1.8°	INSULATION CLASS: B
STEP TO STEP ACCURACY: ±0.09°	BEARINGS: L-940ZZ
POSITION ACCURACY: ±0.09°	TEMP. RISE: 80°C MAX.
HYSTERESIS: N/A%	OPERATING TEMP. RANGE: -20 TO +50°C
SHAFT RUNOUT: 0.03 mm T.I.R. MAX	STORAGE TEMP. RANGE: -30 TO +70°C
RADIAL PLAY: 0.02 mm MAX (0.5 kg RADIAL LOAD)	RELATIVE HUMIDITY RANGE: 15 TO 85%
END PLAY: 0.08 mm MAX (0.5 kg AXIAL LOAD)	WEIGHT: 40 g (1.41 oz ) APPROXIMATE

CONNECTION	RESISTANCE PER PHASE (ohm ±10%)	INDUCTANCE PER PHASE (mH ±20%)	RATED CURRENT (Amp)	HOLDING TORQUE (mNm MIN)	HOLDING TORQUE (oz-in MIN)
BI-POLAR	11.5	3.4	0.35	19	2.69

## NOTES, UNLESS OTHER WISE SPECIFIED:

- 1 MEASUREMENTS MADE AT RATED CURRENT IN EACH PHASE.
- 2 BETWEEN ANY TWO ADJACENT FULL STEP POSITIONS.
- 3 MAXIMUM ERROR IN 360°.
4. HIPOT 500 VAC, 60Hz FOR ONE MINUTE.
- 5 LEADS: 4, 26 AWG, 7 STRAND MIN. UL AND CSA APPROVED. UL 3265
6. INSULATION RESISTANCE: 100 MEGOHMS MIN AT 500 VDC.
- 7 AS MEASURED ACROSS EACH PHASE.
- 8 AS MEASURED ACROSS EACH PHASE USING AN A.C. INDUCTANCE BRIDGE AT 1KHz.
- 9 AS MEASURED BY THE CHANGE IN RESISTANCE METHOD, WITH RATED CURRENT APPLIED TO 2 PHASES: WITH MOTOR AT REST.
- 10 ADD "D" TO END OF PART NUMBER IF DOUBLE SHAFT IS REQUIRED.
11. ROTOR AND STATOR LAMINATED CONSTRUCTION.
12. THIS MOTOR IS MANUFACTURED IN COMPLIANCE WITH CURRENT EU RoHS DIRECTIVE.
- 13 MOTOR LABEL TO INCLUDE AMP LOGO, AMP WEBSITE, "RoHS" COMPLIANCE LOGO, AMP P/N, "MADE IN (COUNTRY)", AND DATE CODE.
- 14 CONNECTOR: JST B6B-ZR(LF)(SN) HOUSING: JST ZHR-6 TERMINAL: JST SZH-002T-PO.5

## REVISIONS

ECO #	REV.	DESCRIPTION	DATE	APPROVED
8470	A	INITIAL RELEASE	5/8/2020	J.KORDIK
8523	B	HOLDING TORQUE 15->19 mNm, LABEL NOTE REVISED	8/10/2020	J.KORDIK

DRIVE SEQUENCE MODEL  
BI-POLAR FULL STEP

STEP	A+	A-	B+	B-
1	+	-	+	-
2	-	+	+	-
3	-	+	-	+
4	+	-	-	+
1	+	-	+	-

CW (CLOCKWISE) AND CCW (COUNTER-CLOCKWISE) ROTATION WHEN SEEN FROM THE FLANGE SIDE OF THE MOTOR

## WIRING DIAGRAM

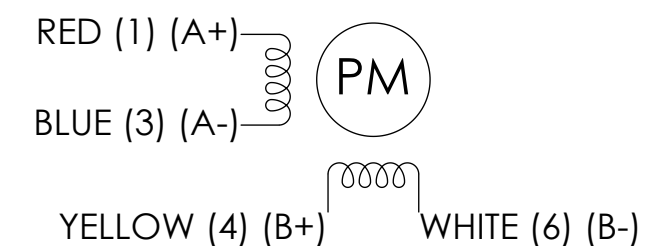

 <p><b>Applied Motion Products</b> A MOONS' COMPANY</p> <p>PROPRIETARY AND CONFIDENTIAL</p> <p>THE INFORMATION CONTAINED IN THIS DRAWING IS THE SOLE PROPERTY OF APPLIED MOTION PRODUCTS. ANY REPRODUCTION IN PART OR AS A WHOLE WITHOUT THE WRITTEN PERMISSION OF APPLIED MOTION PRODUCTS IS PROHIBITED.</p>	UNLESS OTHERWISE SPECIFIED:	NAME	DATE	TITLE:	
	DIMENSIONS ARE IN MILLIMETERS	DRAWN	K.KESLER	8/7/20	STEP MOTOR OUTLINE
	TOLERANCES: ANGULAR: ± 0.5 ONE PLACE DECIMAL ± 0.25 TWO PLACE DECIMAL ± 0.13 THIRD ANGLE PROJECTION	CHECKED	ALAN.N	8/10/20	
	MATERIAL	COMMENTS:			
FINISH				SIZE DWG. NO. REV	
DO NOT SCALE DRAWING				<b>B</b> HT08-230 B	
				SCALE: 1:1 WEIGHT: - SHEET 1 OF 2	

4

3

2

1

4

3

2

1

B

B

A

A

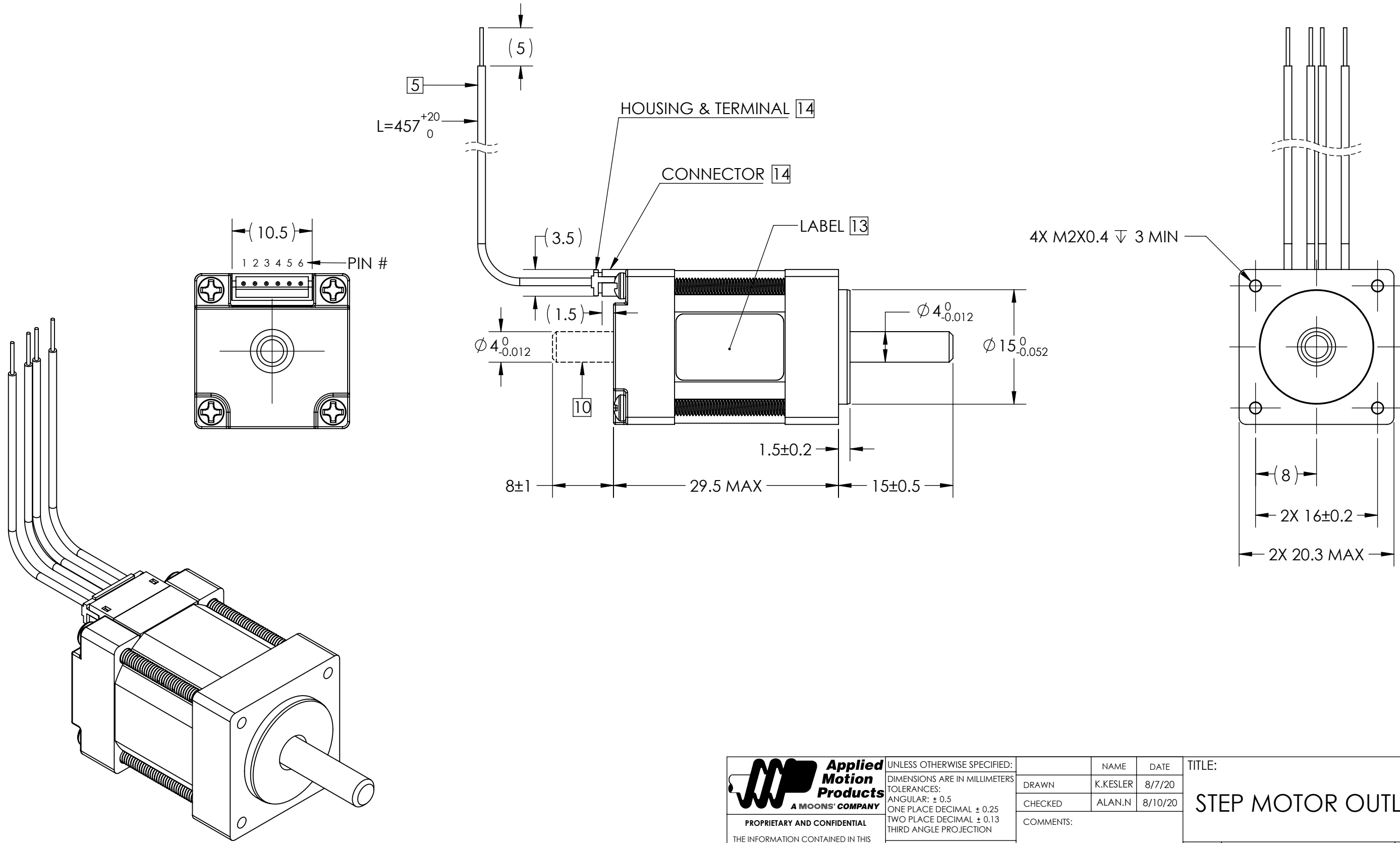

 <p><b>Applied Motion Products</b> A MOONS' COMPANY</p> <p>PROPRIETARY AND CONFIDENTIAL</p> <p>THE INFORMATION CONTAINED IN THIS DRAWING IS THE SOLE PROPERTY OF APPLIED MOTION PRODUCTS. ANY REPRODUCTION IN PART OR AS A WHOLE WITHOUT THE WRITTEN PERMISSION OF APPLIED MOTION PRODUCTS IS PROHIBITED.</p>	UNLESS OTHERWISE SPECIFIED:		NAME	DATE	TITLE:	
	DIMENSIONS ARE IN MILLIMETERS		DRAWN	K.KESLER		8/7/20
	TOLERANCES:		CHECKED	ALAN.N	8/10/20	STEP MOTOR OUTLINE
	ANGULAR: ± 0.5		COMMENTS:			
ONE PLACE DECIMAL ± 0.25					SIZE	
TWO PLACE DECIMAL ± 0.13					DWG. NO.	
THIRD ANGLE PROJECTION					HT08-230	
MATERIAL					REV	
FINISH					B	
DO NOT SCALE DRAWING					SCALE: 2:1	
					WEIGHT: -	
					SHEET 2 OF 2	

4

3

2

1